

GEA HILGE HYGIENIC PUMPS

The comprehensive portfolio
for all liquid processes

GEA HILGE HYGIENIC PUMPS

The heart of every process.

Gentle product handling, continued reliability and economic efficiency are key characteristics of the state-of-the-art hygienic pumps in the GEA Flow Components portfolio.

Our heart pumps for you

What keeps every process system moving for the manufacture of food, beverages, pharmaceuticals and more? Hygienic pumps are applied to processes at the heart of production, in close contact with the product.

GEA offers a multitude of designs for different and often highly sensitive applications: small components, yet an essential part of every system setup.

The success of our customers depends on the quality and profitability of their manufactured products. That's why they rely on GEA's advanced process technology and decades of experience in

ensuring smooth processing. GEA Hilge Hygienic Pumps for all liquid processes meet the highest hygiene standards.

In addition to our hygienic pump portfolio, our range of sophisticated process components also includes hygienic and aseptic valves as well as cleaning technology. All components and services are available worldwide through the international GEA sales network.

GEA Group Aktiengesellschaft

As one of the largest systems suppliers, GEA makes an important contribution to a sustainable future with its solutions and services, particularly in the food, beverage and pharmaceutical sectors. Across the globe, GEA's plants, processes and components contribute significantly to the reduction of CO2 emissions, plastic use as well as food waste in production.



Our heart pumps for you.



Every fourth liter of human blood is handled by GEA equipment.



Around one quarter of the milk processed is handled by GEA equipment.



Roughly every second liter of beer is brewed using GEA equipment and solutions.



Approx. one in three instant coffee lines has been built by GEA.



State-of-the-art pump technology, made to our customers' preferences

At the GEA Hilge Hygienic Pumps Center of Competence in Bodenheim we develop innovative pumps and processes together with our customers. Our decades of up-close experience with operations and systems at our customers' production sites ensure optimum selection and configuration of the right solution for every application.

Maximum efficiency

Two product lines, GEA VARIPUMP and GEA SMARTPUMP, enable our customers to choose from a highly versatile pump range with a multitude of smart adaption options to achieve simpler operation, higher-quality production, and reduced consumption of valuable resources. Special construction features of our pumps provide particularly gentle product handling, delivering top-quality products to our consumers.

Maximum reliability

Our customers rely on the safe, continuous operation of their production systems without unplanned breaks or disturbances. That is why GEA Hilge pumps are optimized for uncompromising reliability in all applications. Thanks to their robust design and long service life, they are known as "workhorses" for their ease of maintenance and outstanding service, proven over decades, and for the great number of pumps currently in operation. Of course,

GEA pumps also comply with all relevant hygiene standards and norms, with continuous documentation and up-to-date certifications safely ensuring judicial security.

Costs under control

Significant cost savings can be achieved by using GEA Hilge pumps. Carefully dimensioned high-efficiency motors ensure low energy consumption. Thanks to simple maintenance, the costs for safeguarding the plant remain manageable.

Long-term partnership

The GEA Hilge Hygienic Pumps Center of Competence in Bodenheim is the contact partner for our customers and partners all over the world for the best possible solution. Delivery and services are provided by GEA's worldwide sales and service network. This ensures all-round support throughout the entire life cycle.

Applications

- Beverage: beer, juices, smoothies
- Dairy: milk, yoghurt, cheese
- Food: sauces, creams, ketchup, chocolate
- Pharma: WFI, vaccines, biochemicals
- Personal care: cosmetics, lotions, shampoos
- Numerous other applications

TWO MODERN PUMP LINES

For every conceivable processing application, the complete GEA pump range gives you peace of mind.

Hygienic pumps are used in processes that directly affect product quality and production. Therefore, the selection and configuration of the right pump requires a lot of experience. The selection matrix for the two pump lines GEA VARIPUMP and GEA SMARTPUMP provides a decision support. The pump types of these two lines are suitable for different requirements and purposes and thus offer the right solution for every application.

The perfect choice

The first parameter to check for selecting the right pump is the complexity of the customer application with regard to the respective system pressures, temperatures and product media.

The second parameter is the required degree of customer-specific adjustment. The overall system concept determines whether standardized pump types or customized engineering will be required.

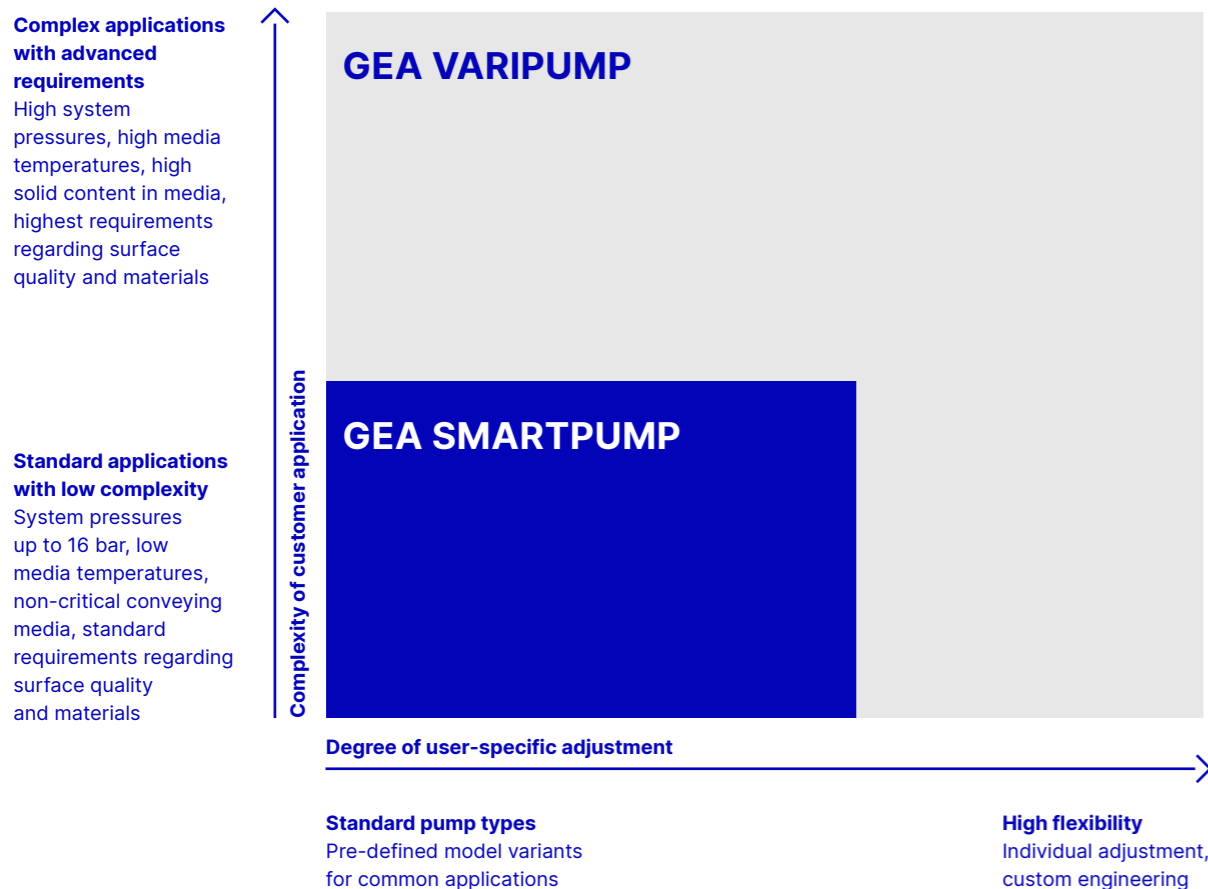

GEA VARIPUMP



GEA SMARTPUMP

GEA VARIPUMP

Choose GEA VARIPUMP

- If a complex application has high requirements.
- If the pump needs to be adapted to customer requirements.

The pump models in the GEA VARIPUMP line are conceived for extreme application demands and are individually optimized for the customer's task. The high quality surfaces, the construction entirely without die-cast components and the high-value materials meet highest demands even in the sensitive pharma industry. The same goes for added services, e.g. Factory Acceptance Test (FAT). Thanks to a great variety of set-up and customizing options the pumps can adapt to any production process, for lower operational costs and more system efficiency. The longevity of the pumps "Made by GEA" ensures a long-term investment.

Characteristics of the GEA VARIPUMP line:

- Developed for advanced application conditions
- Project-specific customization
- Surface roughness up to $Ra \leq 0.4 \mu m$
- Selection of materials in contact with product according to specific requirements (e.g. no die-cast components, $Fe \leq 1\%$)

GEA SMARTPUMP

Choose GEA SMARTPUMP

- If the complexity of the application is low.
- If the predefined variants meet all given requirements.

The GEA SMARTPUMP line covers common, often used applications at standard conditions. The pumps are highly standardized and attractively priced, easy to select and ready for fast delivery. Within the pre-defined parameters, the standard variants can be configured to individual tasks as planned. The modular construction using high-value materials, the proven "Hygienic Design" and the easy-to-apply, standardized spare parts are great reasons to apply GEA SMARTPUMPS pumps in cost-critical production systems – at no compromise in terms of quality.

Characteristics of the GEA SMARTPUMP line:

- Application for common and clearly defined "standard" process tasks
- Simple selection and configuration
- Fast delivery
- Standardized spare parts

GEA HYGIENIC PUMPS

Program Overview

		GEA VARIPUMP	GEA SMARTPUMP	GEA VARIPUMP	GEA SMARTPUMP	GEA VARIPUMP	GEA SMARTPUMP	GEA VARIPUMP			
		Centrifugal pumps						Positive displacement pumps			
		Single-stage			Multi-stage		Self-priming		Rotary lobe	Twin-screw	
		GEA Hilge HYGIA/HYGIA H	GEA Hilge MAXA	GEA Hilge TP	GEA Hilge CONTRA	GEA Hilge DURIETTA	GEA Hilge SIPLA	GEA Hilge TPS	GEA Hilge NOVALOBE	GEA Hilge NOVATWIN	
2-pole, 50 Hz	Max. flow rate [m³/h]	220	320	210	100	8	–	125	up to 2.1 l/rev	up to 310 m³/h	Displacement/ Flow rate
	Max. pump head [m]	77	100	90	200	72	–	95			
	Motor rating [kW]	up to 45.0	up to 90.0	up to 45.0	up to 45.0	up to 2.2	–	up to 45.0			
4-pole, 50 Hz	Max. flow rate [m³/h]	110	1,450	100	–	5	78	–	up to 16	up to 25	Max. differential pressure [bar]
	Max. pump head [m]	18	62	23	–	3	47	–			
	Motor rating [kW]	up to 7.5	up to 160.0	up to 7.5	–	0.25	up to 22.0	–			
2-pole, 60 Hz	Max. flow rate [m³/h]	175	300	240	100	8	–	155	uni-wing bi-wing multilobe	4 screw pitches per size	Rotor design
	Max. pump head [m]	110	100	130	230	41	–	138			
	Motor rating [kW]	up to 45.0	up to 90.0	up to 45.0	up to 45.0	up to 2.2	–	up to 45.0			
4-pole, 60 Hz	Max. flow rate [m³/h]	110	480	120	–	3	64	–	≤ 0.4 / ≤ 0.8	≤ 0.5 / ≤ 0.8	Surface roughness Ra [µm]
	Max. pump head [m]	26	88	34	–	3	60	–			
	Motor rating [kW]	up to 7.5	up to 160.0	up to 7.5	–	0.25	up to 22.0	–			
	Surface roughness Ra [µm]	≤ 0.4 / ≤ 0.8 / ≤ 3.2	≤ 0.8 / ≤ 3.2	≤ 3.2	≤ 0.4 / ≤ 0.8 / ≤ 3.2	≤ 3.2	≤ 3.2	≤ 3.2	1,000,000	1,000,000	Max. viscosity [mPas]
	Surface roughness Ra [µm]	450 – 500, temporarily 1,000			450 – 500	temporarily 1,000	800 – 1,000	500			
	System pressure [bar]	15 / 25 / 64	10	16	25	8	10	16			

APPLICATIONS AND CERTIFICATES

GEA Hilge hygienic pumps are available for all applications in the beverage, food, pharma and personal care sectors, with appropriate certifications available for each industry and region.



Beverage

- The unique, hygienic design prevents contamination of beer and preserves the fine product characteristics.
- Sensitive yeast is conveyed with cells kept fully intact.
- Our pumps serve the highly varying needs of juice manufacturers, maintaining ingredient integrity and the desired viscosity.
- Highly viscous, high-fructose sugar solutions are processed without any problems.



Food

- In confectionery and chocolate production, good taste starts with stable temperature control, precise solids handling and speed control.
- Liquid and pasty foods, such as ketchup, are pumped reliably as well as efficiently.
- Chunky media, e.g. containing nuts or fruits, are handled without problems.



Pharma

- For every conceivable pump application in pharmaceuticals, GEA Hilge pumps can be customized to deliver a fully-documented, hygienic solution.
- For a reliable supply of highly purified water (HPW) or water for injection (WFI), a range of dedicated sterile pumps is available.
- In biochemical processes our range of pumps offers the highest standards and gentle product-handling.



Dairy

- The hygienic pump design and gentle handling keep fresh milk and dairy products just the way they are wanted.
- GEA Hilge pumps maintain product integrity and consistency in dairy processing plants – batch after batch.



Personal Care

- Lotions and creams benefit from the excellent viscosity handling capabilities of the GEA pump range.
- Extremely viscous mixtures, crystalline and corrosive or abrasive media, there's nothing we can't move gently and reliably.
- Shampoos & lotions are pumped efficiently with minimum residues, reducing cleaning effort.

	GEA Hilge HYGIA	GEA Hilge HYGIA H	GEA Hilge MAXA	GEA Hilge TP	GEA Hilge CONTRA	GEA Hilge DURIETTA	GEA Hilge SIPLA	GEA Hilge SIPLA-HT	GEA Hilge TPS	GEA Hilge NOVALOBE	GEA Hilge NOVATWIN
Application											
Beverage	•	•	•	•	•	•	•	•	•	•	•
Food	•	•		•	•		•	•	•	•	•
Pharma	•	•			•			•	•	•	•
Dairy	•	•	•	•	•	•	•	•	•	•	•
Personal Care	•	•		•	•			•	•	•	•
Document											
3-A Sanitary Standard	•	•		•					•		•
EHDG certificate	•*	•*		•	•*				•*	•*	•*
FDA declaration of conformity	•	•	•	•	•	•	•	•	•	•	•
Declaration of compliance with the order 2.1 acc. to EN 10204	•	•	•		•	•	•	•		•	•
Test report 2.2 acc. to EN 10204	•	•	•	•	•	•	•	•	•	•	•
Inspection certificate 3.1 acc. to EN 10204	•	•	•	•	•		•	•	•	•	•
EAC-Certificate	•	•	•	•	•	•	•	•	•	•	•
Surface roughness test report	•	•	•	•	•			•		•	•
Delta ferrite test report	•	•			•					•	•
Acoustic measurement test report	•	•	•	•	•	•	•	•	•	•	•
USP Class VI – declaration of conformity	•	•		•	•		•	•	•	•	•
Certificate in acc. with the regulation (EG) No. 1935/2004	•	•	•	•	•	•	•	•	•	•	•
Certificate DIN EN ISO 9001:2015	•	•	•	•	•	•	•	•	•	•	•

Many more certificates on request. Subject to change without notice.

* registered for certification/recertification

GEA HILGE HYGIA



The premium pump series GEA Hilge HYGIA consists of single-stage end-suction centrifugal pumps, designed for use in industries with high demands to hygiene and flexibility.

The materials used for GEA Hilge HYGIA pumps have been selected for the use in hygienic processes. The housings are made of CrNiMo rolled steel (1.4404/1.4435) and have a smooth surface without pores and blowholes (Hygienic Design).

GEA Hilge HYGIA pumps are ideally adaptable to customer needs and demanding tasks thanks to variable connections, seals, mountings, infinitely adjustable pressure port and housing variants for up to 25 bar system pressure.

The “Swiss knife” among hygienic pumps

- Process safety, reliability, and optimal cleanability, due to sterile, cast-free stainless steel, deep-drawn or forged components.
- Thanks to the mechanical seal optimally positioned in the pump, a flushed version can often be avoided.
- Precise sizing for optimum efficiency and matching of duty point thanks to different impeller geometries. Additional flexibility

through operation on a frequency converter.

- Gentle conveying of liquids containing solids (e.g. cheese curd), insensitive to solids (grape panicles, pulp, long fibers in concentrate) due to the large clearance between impeller and pump housing as well as special free-flow impeller.
- Facilitated system qualification due to extensive customer- and requirement-specific documentation and certificates.
- When installed vertically, the pump is completely self-draining without a drain valve.
- Service-friendly, quick-opening pump housing. One sealing concept for the entire centrifugal pump portfolio (single-stage, multi-stage, self-priming pumps) minimizes wearing parts logistics.
- The Adapta version enables quick and easy motor change, pump can remain in the pipeline (requires no revalidation in pharmaceutical applications).

GEA Hilge HYGIA performance curves

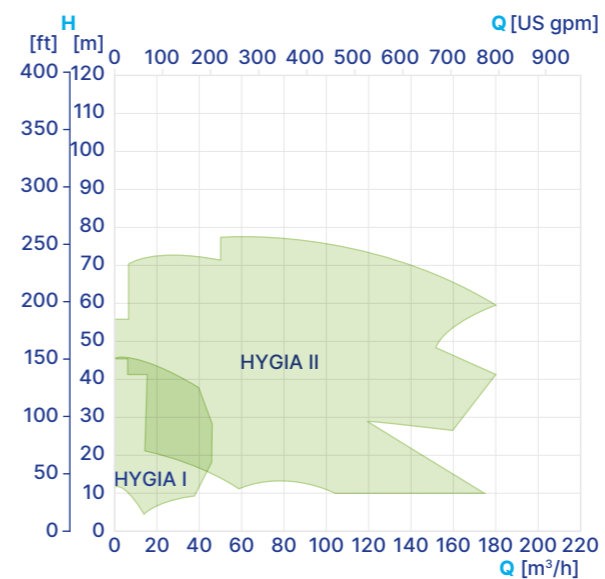

2-Pole, 50 Hz

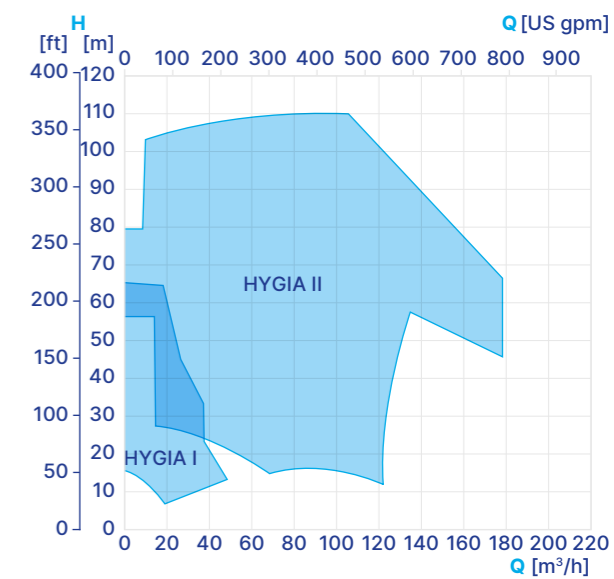

2-Pole, 60 Hz

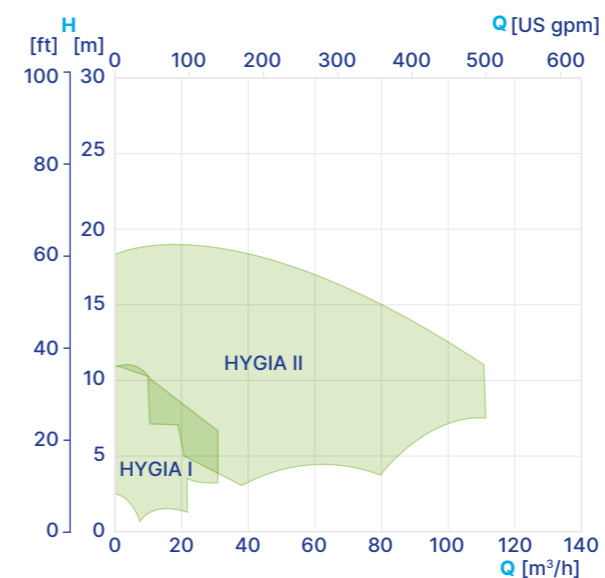

4-Pole, 50 Hz

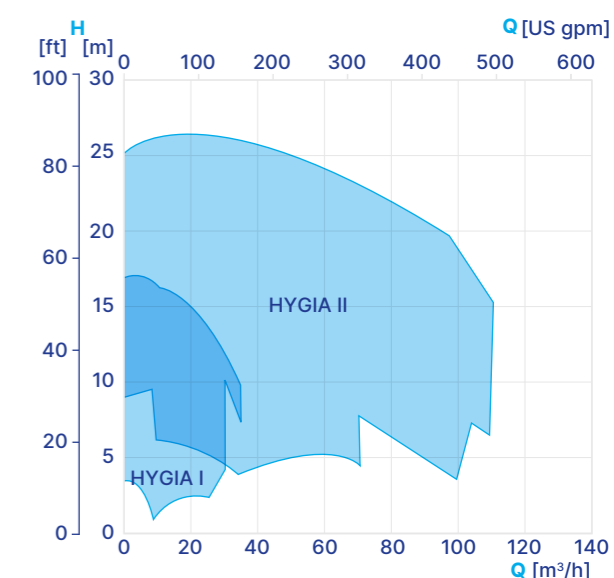

4-Pole, 60 Hz

GEA HILGE HYGIA H

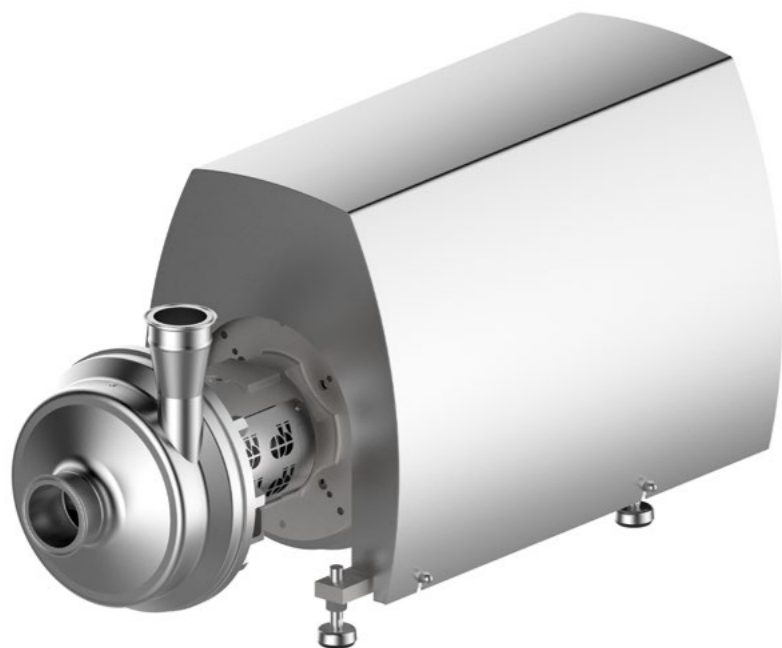

GEA Hilge HYGIA H is a single-stage centrifugal pump designed for high system pressures of up to 64 bar, ideal for membrane filtration processes such as reverse osmosis (RO) and nanofiltration (NF).

For the GEA Hilge HYGIA H, only cast-free stainless steels with pore- and blowhole-free surfaces are used in the product-contact area. The 3-A-certified series is based on the well-known GEA Hilge HYGIA design without dead ends and can be used in all industries with high demands on hygiene and reliability.

The robust design with forged components, the use of standard motors and a sealing concept that is individually tailored to the respective pumped medium make the GEA Hilge HYGIA H a flexible series that can be used in numerous areas of application in which a reliable, hygienic pump function is required.

High-pressure version of the proven HYGIA series

- Process safety, reliability and optimal cleanability at system pressures up to 64 bar.
- Sterile, cast-free stainless steel variant with

deep-drawn or forged components without blowholes (Hygienic Design).

- Precise sizing for optimum efficiency and matching of duty point thanks to selectable impeller geometries. Additional flexibility through operation on a frequency converter.
- Corrosion-free bearing bracket made of stainless steel.
- The Adapta version enables quick and easy motor change, pump can remain in the pipeline (requires no revalidation in pharmaceutical applications).
- Ideally adaptable to customer needs and demanding tasks thanks to different seal designs.
- Facilitated system qualification due to extensive customer- and requirement-specific documentation and certificates.
- Minimized wear part inventory, only 3 seal sizes for the entire performance range.

GEA Hilge HYGIA H performance curves

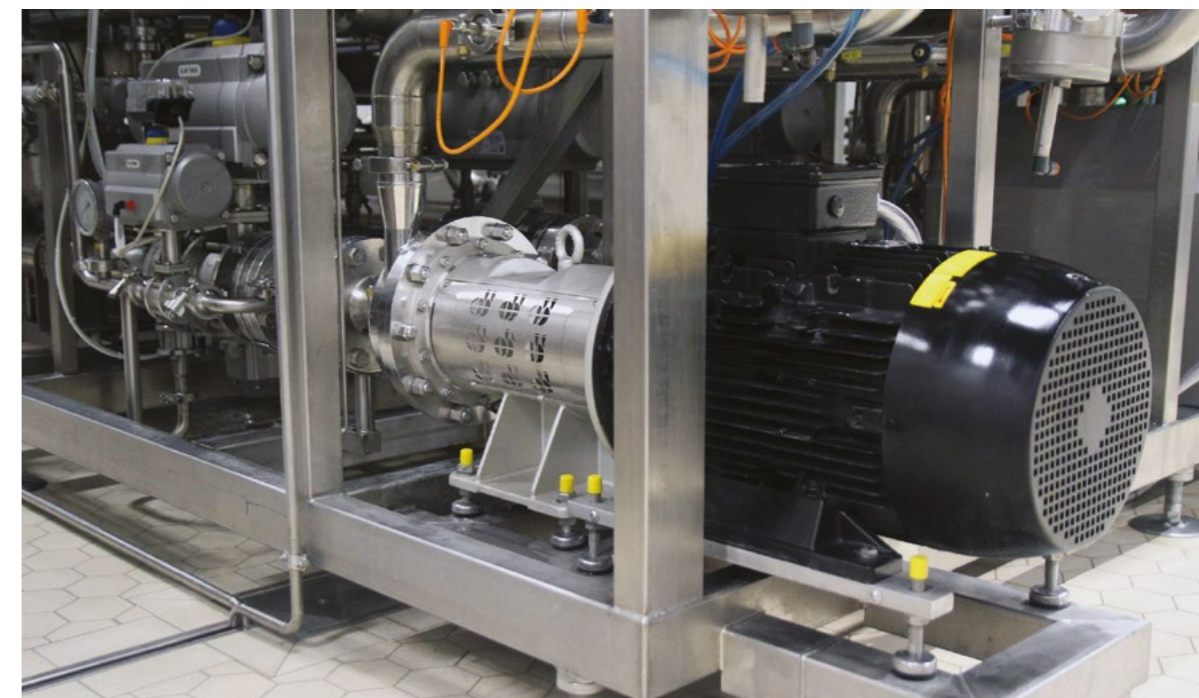
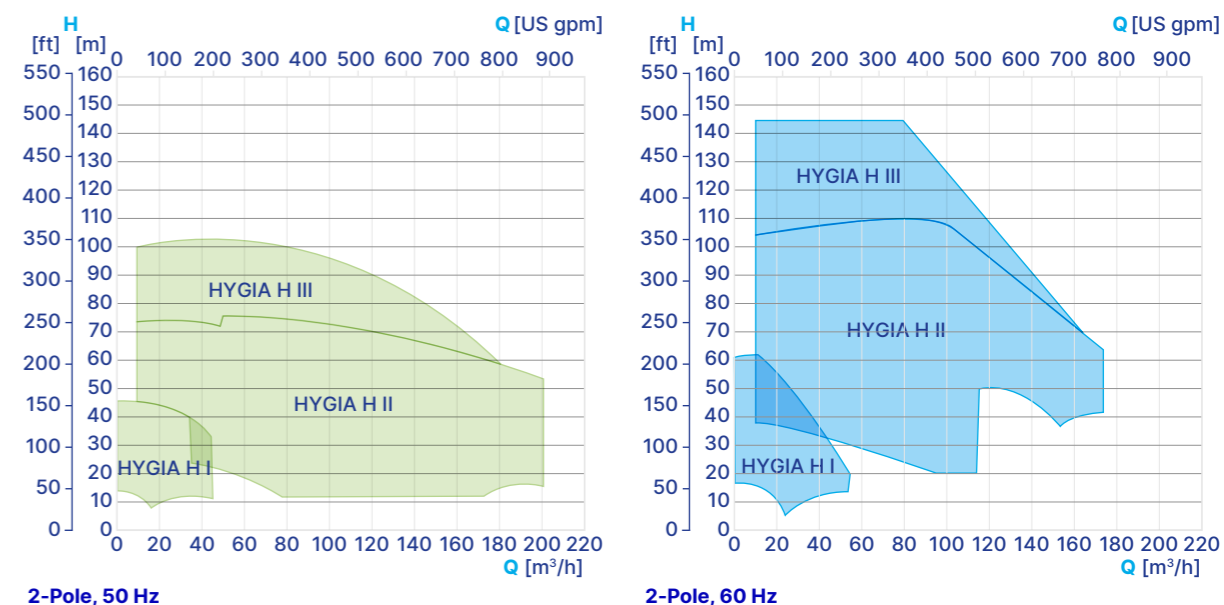

GEA HILGE MAXA

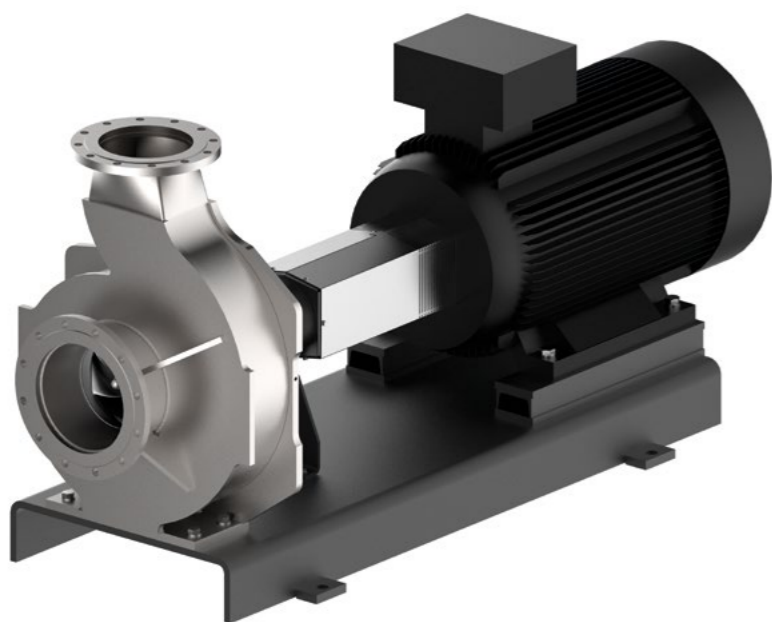

The GEA Hilge MAXA range offers single-stage end-suction centrifugal pumps designed for heavy-duty operation in industrial processes.

The GEA Hilge MAXA range is made in a durable, robust construction from welded, rolled stainless steel in AISI 316L (1.4404). Flexible mounting options are available, such as a close-coupled pump, a close-coupled pump with bearing bracket or a base plate pump version (with motors up to 160 kW).

The “big baby” among hygienic pumps

- Great capacity range – up to 1,450 m³/h (6,384 US gpm).
- Ensuring process reliability and certified cleanability based on the water pump norm DIN EN 733.
- Standard mechanical seal according to DIN 24960.

- Ideally adaptable to customer needs and demanding tasks thanks to variable connections and mountings. Special version available for abrasive media.
- Handling of media containing solids up to 20 mm possible through different closed impeller geometries.
- Space-saving compact design available through close-coupled variant.
- The bearing bracket design enables a quick and easy motor change where the pump can remain in the pipeline.
- Favorable spare parts inventory thanks to only four shaft diameters for 17 pump sizes.

GEA Hilge MAXA performance curves

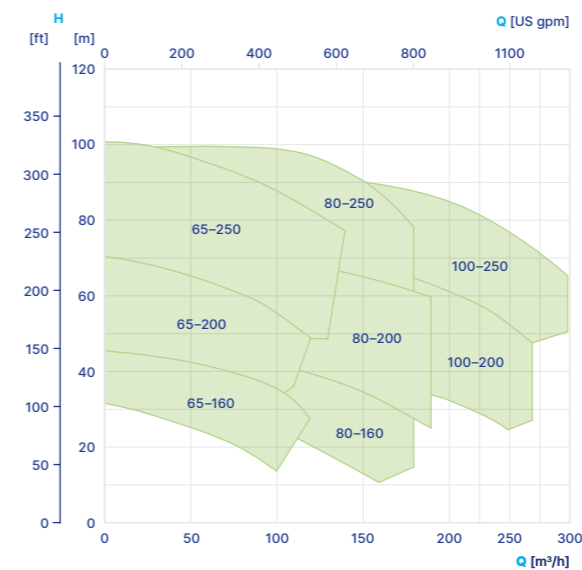

2-Pole, 50 Hz

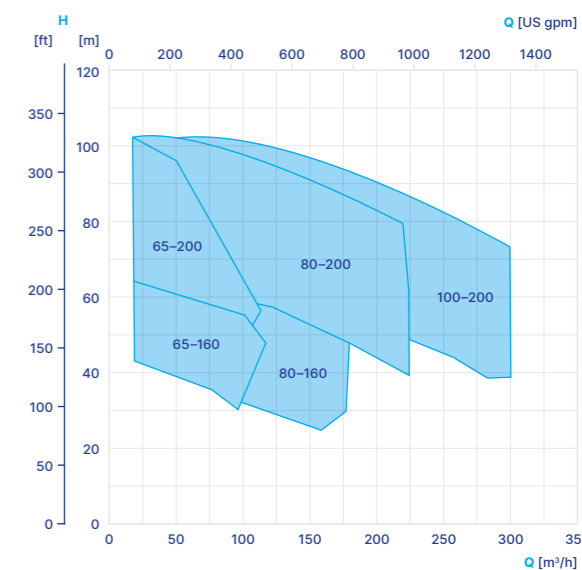

2-Pole, 60 Hz

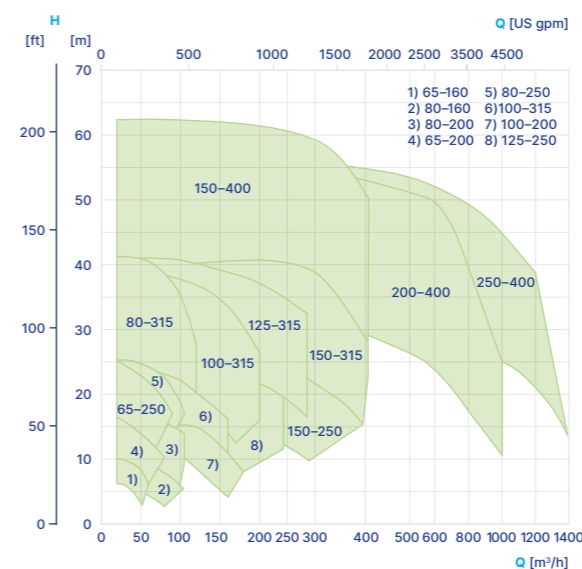

4-Pole, 50 Hz

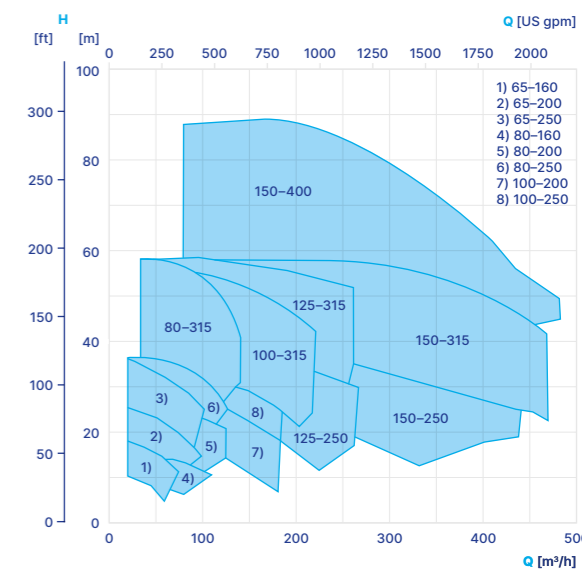

4-Pole, 60 Hz

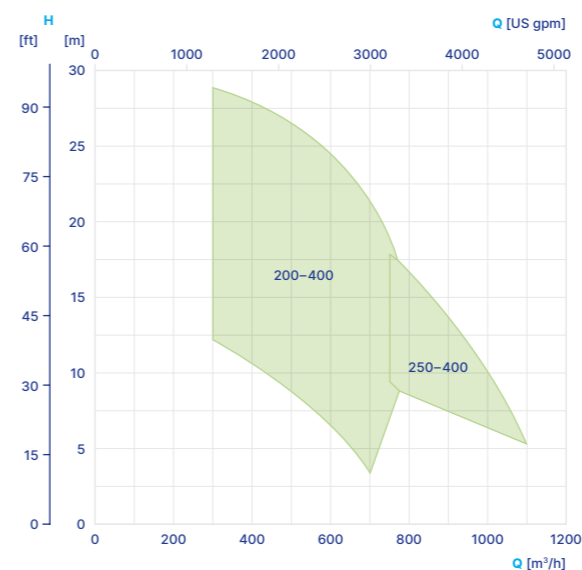

6-Pole, 50 Hz

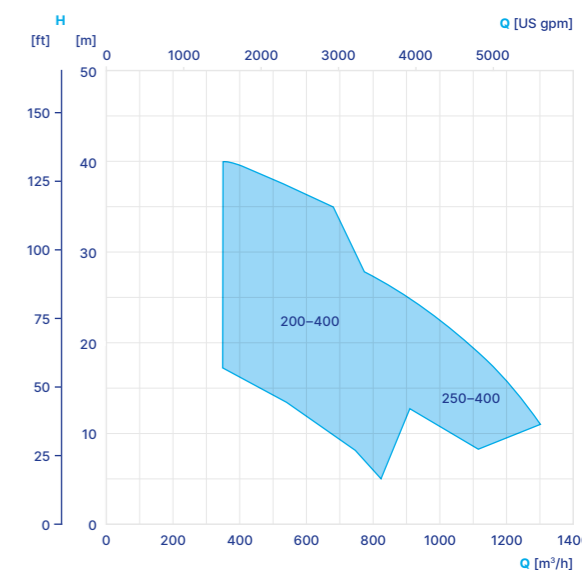

6-Pole, 60 Hz

GEA HILGE TP



The energy-efficient and hygienic GEA Hilge TP centrifugal pumps are available in a variety of model sizes, optimally configured for different applications.

The centrifugal pump GEA Hilge TP is designed for the hygienic pumping in different applications. Low flow velocities and gentle discharge of media through the spiral housing enables extremely gentle product handling. 11 different pump sizes are available covering a large capacity range, fine-tuned for each task.

Standardized for fast delivery

- Process safety, reliability, and optimal cleanability, due to sterile, cast-free stainless variant with blowhole-free, deep-drawn components (Hygienic Design).
- Gentle product handling of liquids thanks to optimum impeller geometry.

- Precise sizing for optimum efficiency and matching of duty point thanks to different impeller geometries. Additional flexibility through operation on a frequency converter.
- Fast delivery time thanks to a standardized product portfolio.
- Modular system for easy adaptation to changing requirements (e.g. self-priming, other mechanical seals).
- Favorable spare parts inventory thanks to the same sealing concept as TPS pumps and only 2 seal diameters for 11 pump sizes.
- Simple and economical motor replacement by IEC or NEMA standard motor with balanced clamping shaft.

GEA Hilge TP performance curves

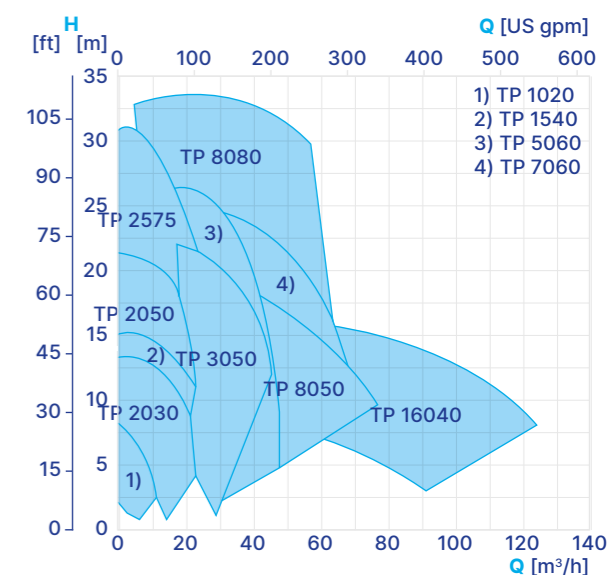
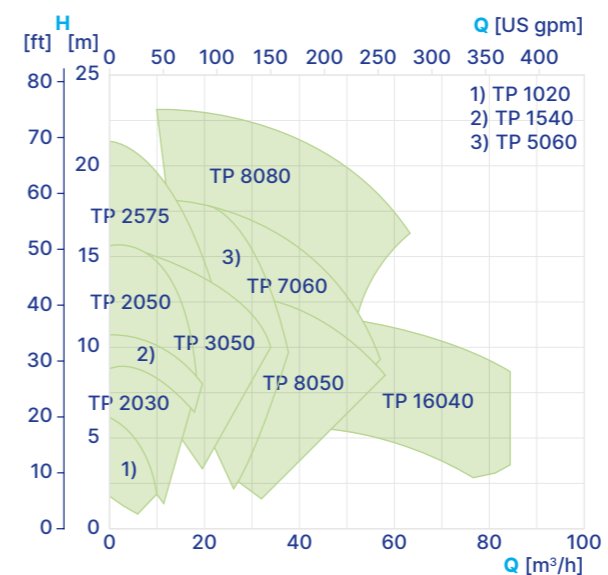
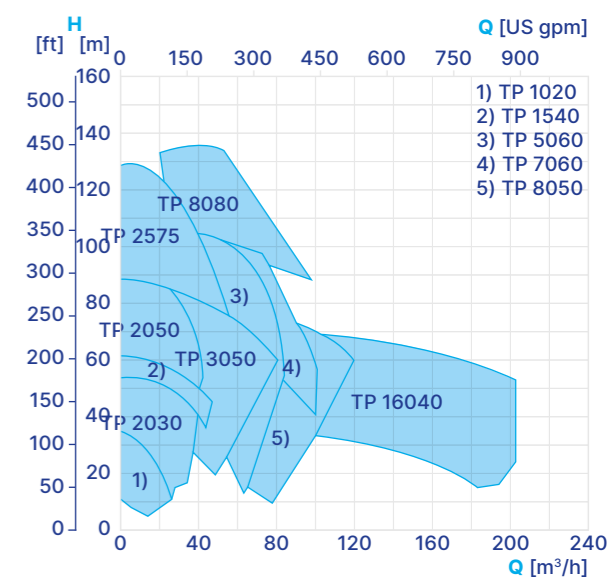
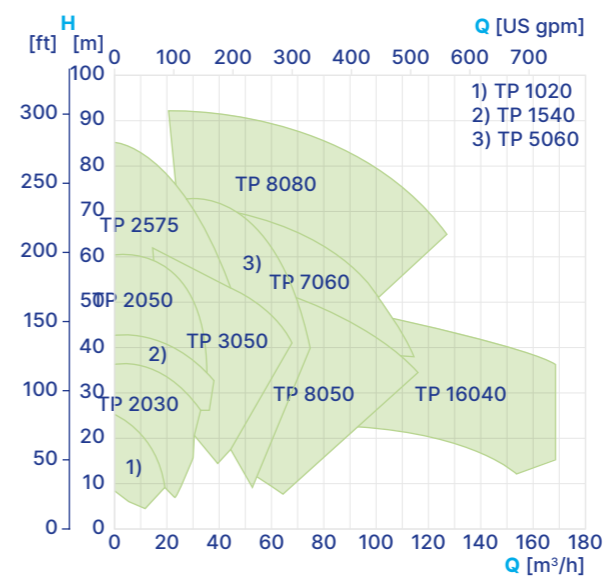

GEA HILGE CONTRA



The GEA Hilge CONTRA range offers single- and multi-stage end-suction centrifugal pumps designed in accordance with the Qualified Hygienic Design (QHD) criteria for hygienically safe product handling and maximum adaptation options.

GEA Hilge CONTRA pumps are especially smooth and quiet in operation due to the balanced construction of the pump hydraulics and high motor efficiency. Apart from DIN, ASME and ANSI connections, a flexible range of custom connections is available upon request.

The "stage master" pump for demanding processes

- Process safety, reliability, and optimal cleanability, due to sterile, cast-free stainless steel, deep-drawn or forged without blowholes (Hygienic Design).
- When installed vertically, the pump is completely self-draining without a drain valve.
- Ideally adaptable to customer needs and demanding tasks thanks to variable connections, seals and mountings.
- Precise sizing for optimum efficiency and

matching of duty point thanks to selectable impeller geometries. Additional flexibility through operation on a frequency converter.

- Great flow and pressure control thanks to the steep performance curve.
- Gentle handling of shear-sensitive media thanks to very low NPSH values, minimizing cavitation and wear.
- The Adapta version enables quick and easy motor change, the pump can remain in the pipeline (requires no revalidation in pharmaceutical applications).
- Facilitated system qualification due to extensive customer- and requirement-specific documentation and certificates.
- One sealing concept for the entire centrifugal pump portfolio (single-stage, multi-stage, self-priming pumps) minimizes wearing parts logistics.

GEA Hilge CONTRA performance curves

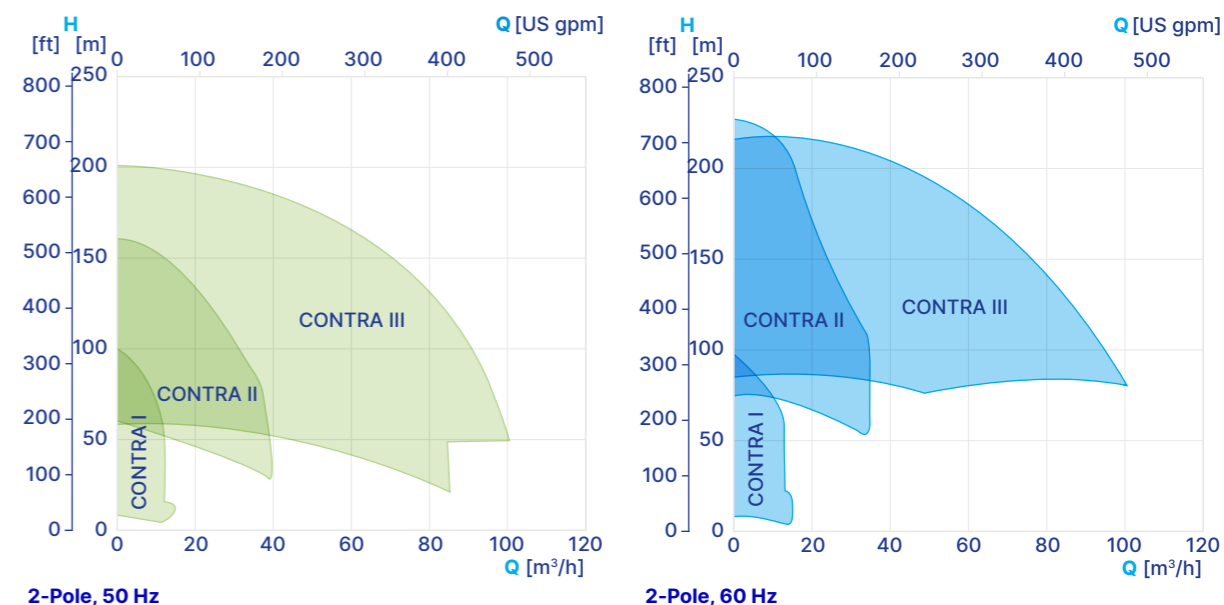

GEA HILGE DURIETTA

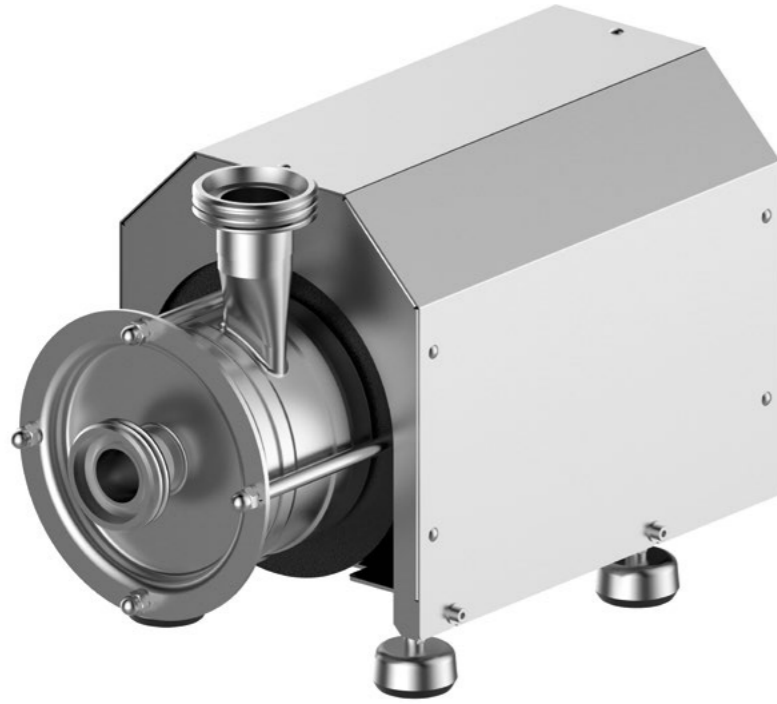

The GEA Hilge DURIETTA is a close-coupled, end-suction, single- or multi-stage centrifugal pump created for all kinds of standard applications under hygienic conditions.

The GEA Hilge DURIETTA is designed in compliance with food technology requirements, making the range ideal for jobs where hygiene is a key concern. It is CIP- and SIP-capable with the performance characteristics outlined for pumps in DIN 12462.

Compact and space-saving for low flow rates

- Fast delivery time thanks to a standardized product portfolio.
- Different sealing systems for optimal solutions in different applications.

- High head pressures and high efficiency due to the multi-stage design.
- Good flow and pressure control thanks to the steep performance curve.
- Process safety, reliability, and optimal cleanability, due to sterile, cast-free stainless steel, deep-drawn variant without blowholes (Hygienic Design).
- Versatile use with the mobile pump version.
- Favorable wear parts inventory with the GEA Hilge cross-series sealing concept.

GEA Hilge DURIETTA performance curves

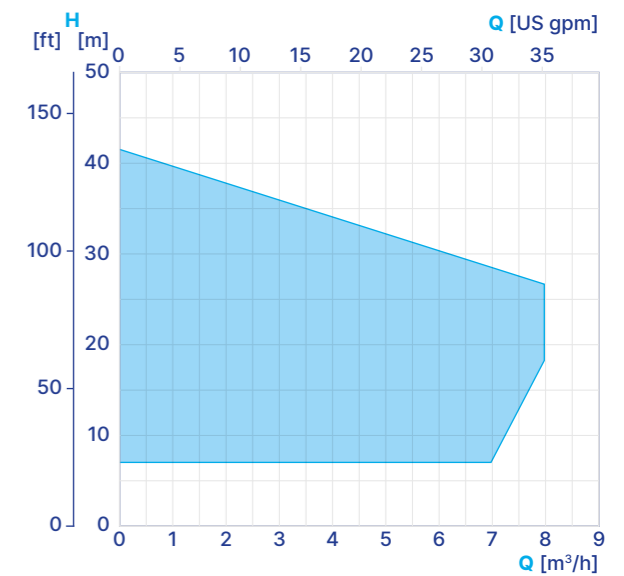
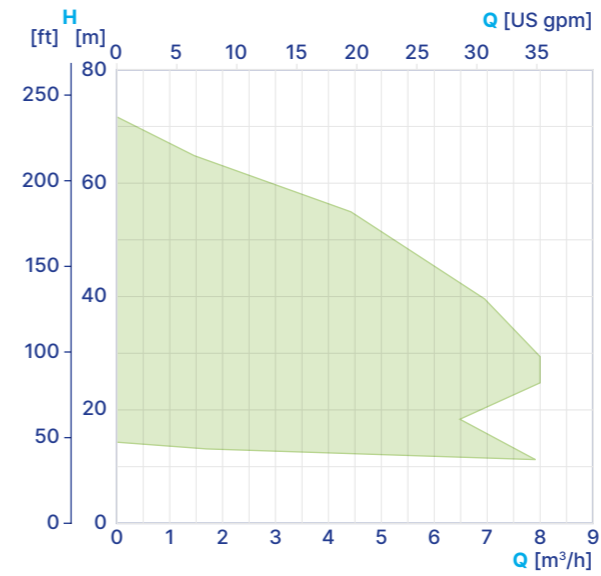

GEA HILGE SIPLA



The GEA Hilge SIPLA range offers self-priming side channel pumps for demanding applications, high reliability and smooth operation for the success of your production and cleaning processes.

The GEA Hilge SIPLA range of self-priming side channel pumps offers clockwise and counterclockwise rotation e.g. for facilitated CIP processes. The top casing connections ensure that the pump is not drained when not running. Robustness characterizes the components of the GEA Hilge SIPLA family. The all-stainless steel construction exemplifies GEA's commitment to quality and efficiency.

The "CIP return master" for optimized cleaning

- Good suction performance ensures shorter process times even when pumping media with high gas content.
- Ensured process flexibility due to clockwise and counter-clockwise rotation in the standard version (a particular advantage for mobile pumps).

- Suitable for pumping both product and CIP liquid, greatly reducing investment costs.
- Ideally adaptable to customer needs and demanding tasks, thanks to variable connections, seals and mountings.
- The Adapta version enables quick and easy motor change, pump can remain in the pipeline.
- One sealing concept for the entire centrifugal pump portfolio (single-stage, multi-stage, self-priming pumps) minimizes wearing parts logistics.
- Long service life of wear parts thanks to low vibration.

GEA Hilge SIPLA performance curves

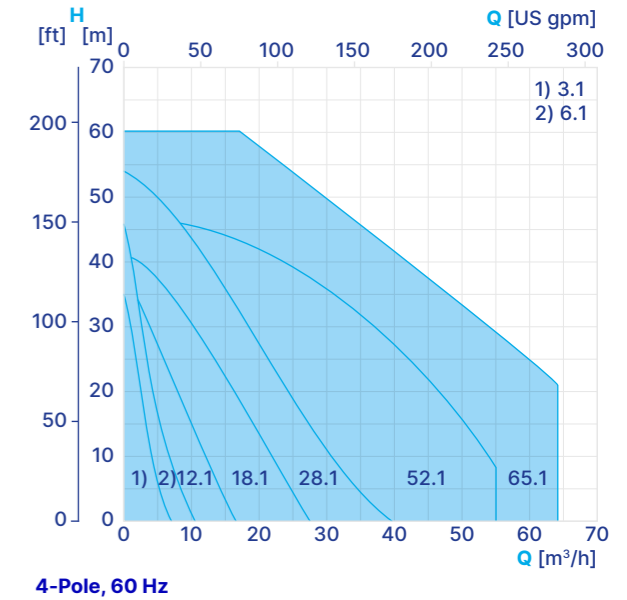
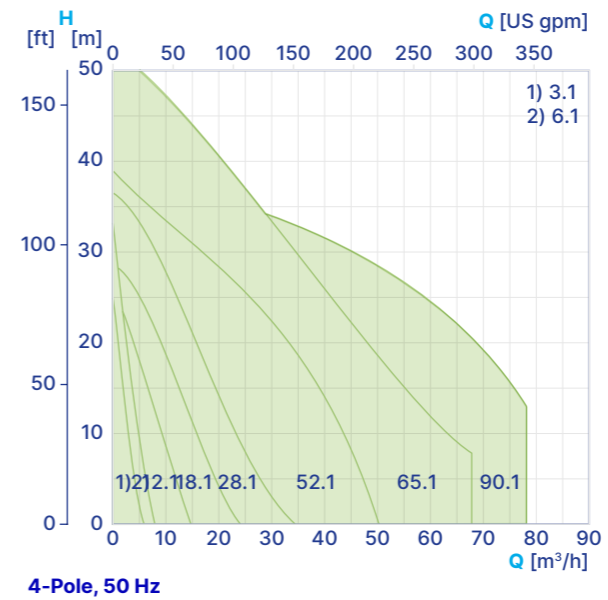

GEA HILGE SIPLA-HT



With the continuous Qualified Hygienic Design (QHD) and use of pore- and blowhole-free materials, GEA Hilge SIPLA-HT pumps are used in the food and beverage as well as in the pharmaceutical, biotech and personal care industries.

These self-priming pumps offer a long operating life even under the harshest operating conditions, e.g. pumping media with a high gas content, or in CIP return systems. The SIPLA-HT can be optionally equipped with an integrated frequency converter for speed control.

Special variant for pharma applications

- Parts in contact with the product made of milled stainless steel, free of cast material and blowholes; Ra ≤ 0.4 μm; ferrite content ≤ 1%.
- Robust high-precision construction with

optimized hydraulic design for better efficiency, high-quality materials for high reliability in operation.

- Sealing options with single and double mechanical seals for effective cleaning, cooling and lubrication.
- Star impeller for reliable and efficient handling of pumped media with a high gas content.
- The Adapta version enables quick and easy motor change, the pump can remain in the pipeline (requires no revalidation in pharmaceutical applications).

GEA Hilge SIPLA-HT performance curves

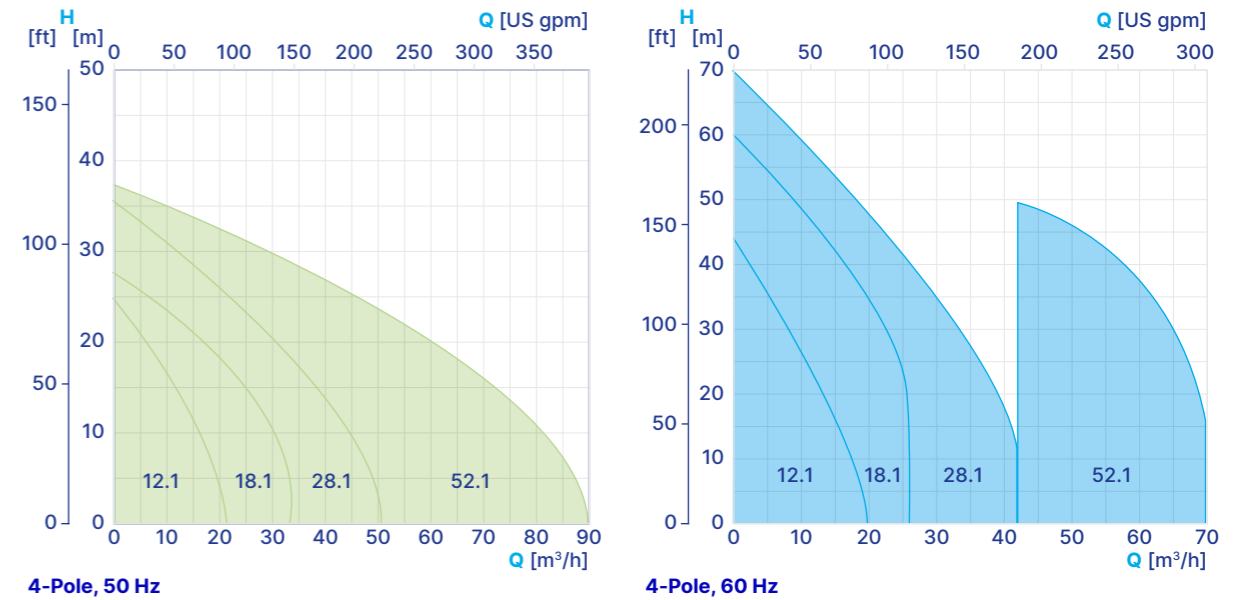

GEA HILGE TPS

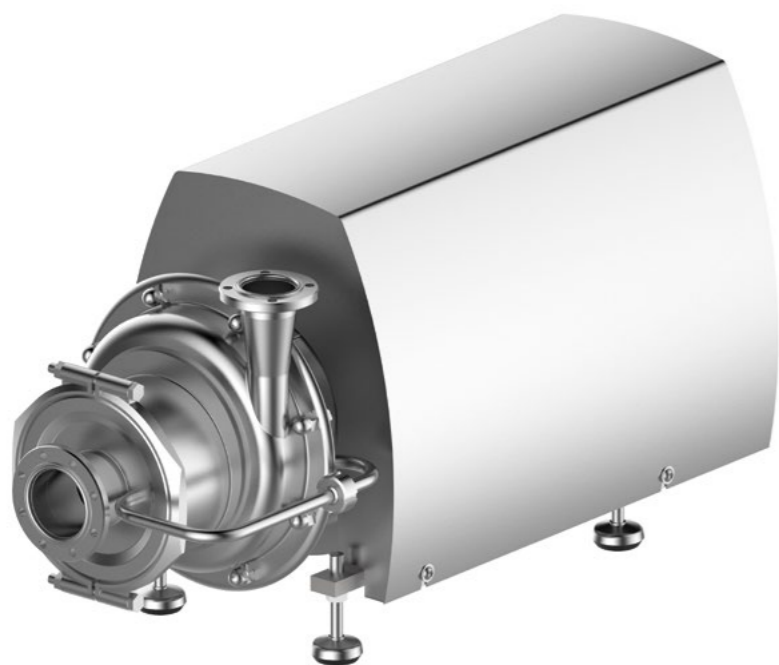

The self-priming, hygienic GEA Hilge TPS centrifugal pumps are available in four model sizes and are optimized for a variety of applications.

The centrifugal pump GEA Hilge TPS is a self-priming pump for viscosities of up to 500 mPas. The TPS is characterized by a low sound level, highest efficiency and excellent cleaning properties. The GEA Hilge TPS series also permits evacuation of pipes on the suction side – so that just one pump is required for CIP return and product conveying.

The 2-in-1 pump for product and CIP

- Self-priming pump for both CIP process and gentle product handling, reducing investment costs.
- Precise sizing for optimum efficiency and matching of duty point thanks to different impeller geometries. Additional flexibility through operation on a frequency converter.

- Modular system for easy adaptation to changing requirements (e.g. different impeller size or other mechanical seals).
- Also suitable for large systems and long pipelines due to the extensive performance range.
- More quiet in operation compared to side channel pumps.
- Simple and economical motor replacement by IEC or NEMA standard motor with balanced clamping shaft.
- Process safety, reliability, and optimal cleanability, due to sterile, cast-free stainless steel, deep-drawn variant without blowholes (Hygienic Design).
- Favorable spare parts inventory with same sealing concept as TP pumps.

GEA Hilge TPS performance curves

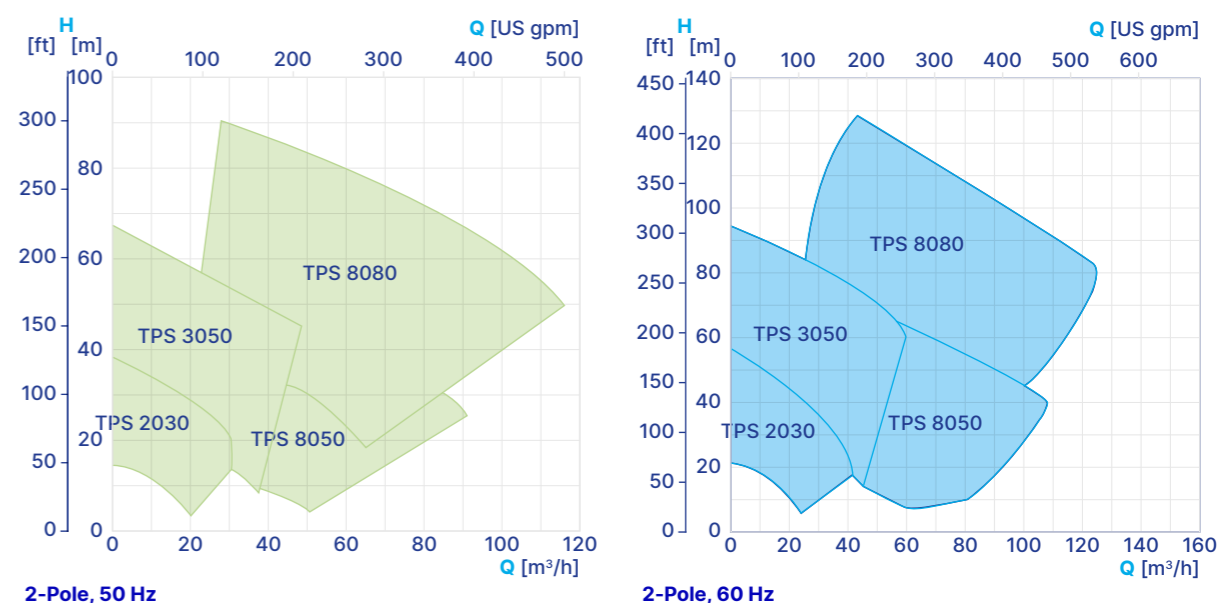

GEA HILGE NOVALOBE

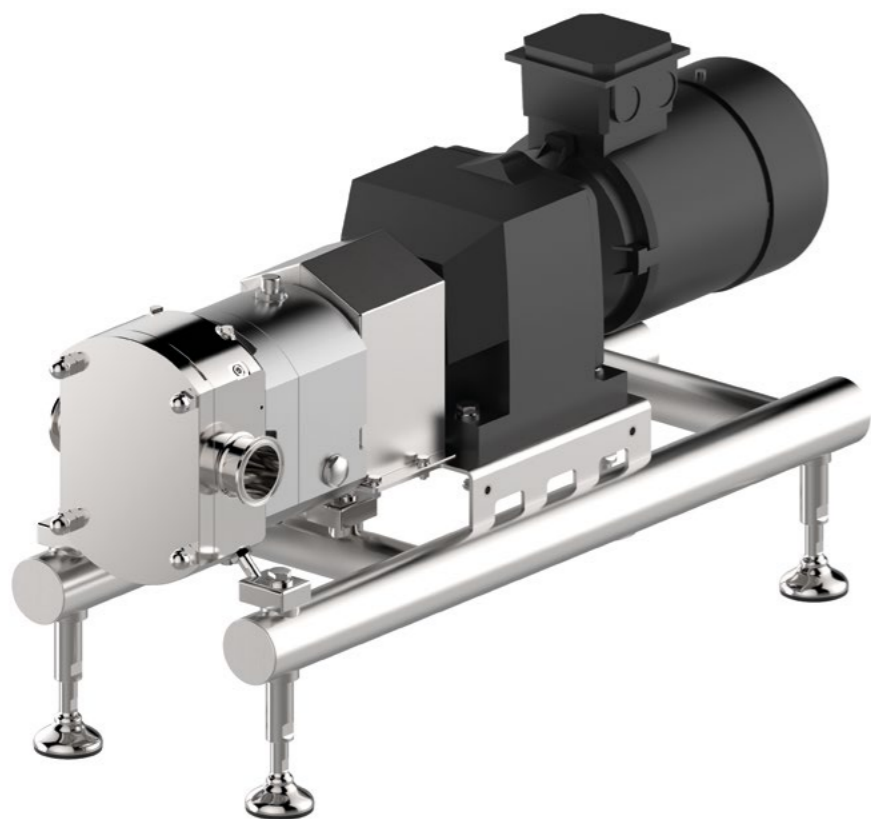

The GEA Hilge NOVALOBE range comprises innovative pumps that have been specifically designed for the smooth handling of highly viscous media.

Through the pump's robust construction the shaft overhang and clearance in the pump have been minimized. The pump's compact design and the rigid shaft geometry reduce the risk of galling to an absolute minimum.

The "smooth operator"

- Long-term reliability thanks to robust pump design and well-flushed shaft seal.
- Gentle and safe conveying of the product, no metal-to-metal contact.
- Process safety, reliability, and optimal cleanability, due to sterile, cast-free stainless steel, deep-drawn or forged without blowholes (Hygienic Design).

- Ideally adaptable to customer needs and demanding tasks thanks to great variability of rotary lobe geometries, connections, seals, and mountings.
- Fast and easy seal servicing thanks to mechanical seals accessible from the front (pump can remain in the pipeline).
- Small machine footprint due to compact design.
- Facilitated system qualification due to extensive customer- and requirement-specific documentation and certificates.
- When mounted in vertical connection position, the pump is completely drainable without drain valve.

Program Overview

Pump model	NOVALOBE 10/0.06	NOVALOBE 20/0.12	NOVALOBE 30/0.33	NOVALOBE 40/0.65	NOVALOBE 50/1.29	NOVALOBE 60/2.1
Displacement (l/rev)	0.06	0.12	0.33	0.65	1.29	2.1
Differential pressure (bar)	16	16	16	16	16	10
Max. speed (rpm)	1,500	1,500	1,250	1,000	800	500
Max. liquid temperature	up to 95 °C, 150 °C (SIP)	up to 95 °C, 150 °C (SIP)	up to 95 °C, 150 °C (SIP)	up to 95 °C, 150 °C (SIP)	up to 95 °C, 150 °C (SIP)	up to 95 °C, 150 °C (SIP)
Rotor design	uni-wing bi-wing multilobe	uni-wing bi-wing multilobe	uni-wing bi-wing multilobe	uni-wing bi-wing multilobe	uni-wing bi-wing multilobe	bi-wing multilobe
Surface roughness Ra (µm)	≤ 0.8 / ≤ 0.41	≤ 0.8 / ≤ 0.41	≤ 0.8 / ≤ 0.41	≤ 0.8 / ≤ 0.41	≤ 0.8 / ≤ 0.41	≤ 0.8 / ≤ 0.41
Connection size (mm)	25	40	50	65	80	100
Max. particle size (mm) (non-abrasive)	12	16	23	29	35	41
Max. viscosity (mPas)	1,000,000	1,000,000	1,000,000	1,000,000	1,000,000	1,000,000

1. GEA Hilge NOVALOBE with thermal jacket



2. GEA Hilge NOVALOBE 60 on sterile base frame with stainless steel shroud



3. GEA Hilge NOVALOBE 10 vertical



4. GEA Hilge NOVALOBE with pressure relief valve



5. Rotor designs uni-wing, bi-wing and multilobe



GEA HILGE NOVATWIN

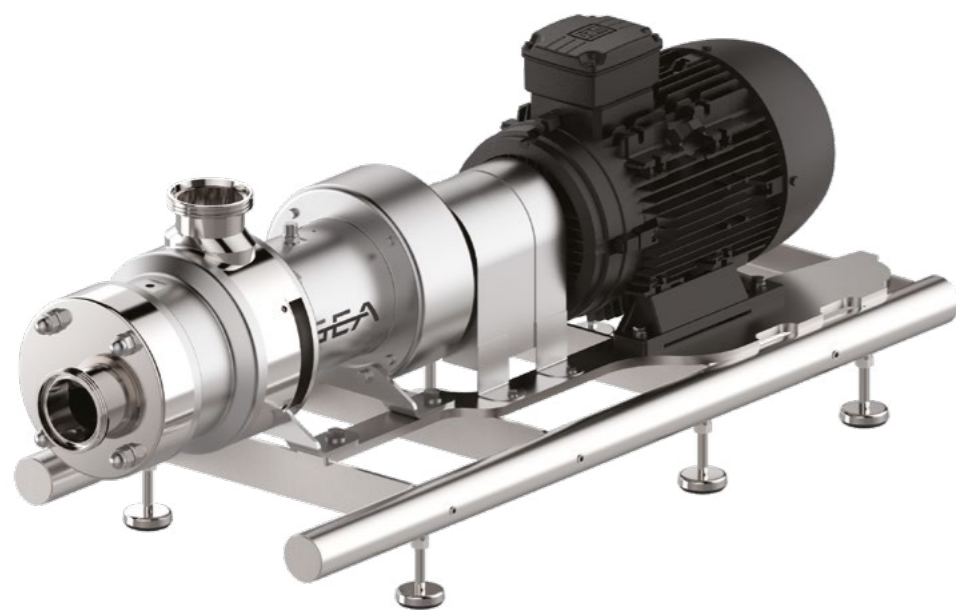

GEA Hilge NOVATWIN is a flexible twin screw pump that meets the highest hygienic requirements. It enables sensitive media to be conveyed at low speed as well as CIP cleaning by variable speeds up to 3000 rpm, with only one pump.

The robust design of the pump, proven over many years, ensures reliable operation. The name NOVATWIN stands for more than 150 years of pump experience.

2-in-1 twin screw pump

- Thanks to the gentle and low-pulsation conveying, even sensitive products with large particles remain intact.
- Flexible pump for both product and CIP, saving investment, adaption time, expense, and labor.
- Good suction performance due to tight manufacturing tolerances and narrow gaps in the pump.

- The pump's hygienic design ensures quick and safe cleanability, saving time and resources while increasing production safety.
- Hardened surfaces allow easy handling of abrasive media.
- Ideally adaptable to customer needs and demanding tasks thanks to numerous combinations of screw diameters and pitches.
- Facilitated system qualification due to extensive customer- and requirement-specific documentation and certificates.
- Thanks to its hygienic design, the pump can be emptied completely without a drain valve.

Program Overview

NOVATWIN		10 / 15	20 / 25	30 / 35	40 / 45	50 / 55	60 / 65
	Product	12	30	65	125	215	310
Max. flow rate (m ³ /h)	CIP	20	50	115	160	215	310
Max. differential pressure (bar)		16	25	25	25	25	25
	Product	1,760	1,760	1,760	1,760	1,760	1,760
Max. speed (rpm)	CIP	3,000	3,000	3,000	3,000	2,400	2,000
Standard connection size (mm)		50	65	80	100	125	150
Max. particle size (mm)		17 / 25	25 / 33	31 / 43	38 / 53	46 / 62	55 / 74

1. GEA Hilge NOVATWIN on base frame and stainless steel shroud

2. GEA Hilge NOVATWIN bare-shaft pump

3. More than 40 different combinations of screw diameters and pitches available



GEA HILGE NORM-DURACHROM



The GEA Hilge Norm-Durachrom series complements the GEA hygienic pump range as a standard water pump, in order to be able to cover all areas with the appropriate pumps for our customers.

The robust design and standardized connection dimensions ensure good interchangeability. The GEA Hilge Norm-Durachrom is characterized by simple maintenance, as well as by the use of IEC standard motors, which can be easily replaced if necessary. GEA Hilge thus offers proven product quality for all applications from one source.

The norm pump

- Single stage, normal priming standard pump.
- Pump heads up to 90 m and flow rates up to 240 m³/h.
- Operating pressure up to 10 bar.

- Media temperature -10 °C to +90 °C.
- Nominal connection diameters from DN 32 to DN 100.
- Motor power from 0.25 kW–55 kW.
- Impeller, casing and shaft made of Cr-Ni rolled steel (AISI 304 / AISI 316).
- Mechanical seals: Carbon/stainless steel/EPDM or SiC/SiC/Viton.
- Process construction in “back pull-out” design, whereby the entire pump hydraulics including motor are pulled out to the rear and the pump casing remains in the pipeline.

GEA Hilge Norm-Durachrom performance curves

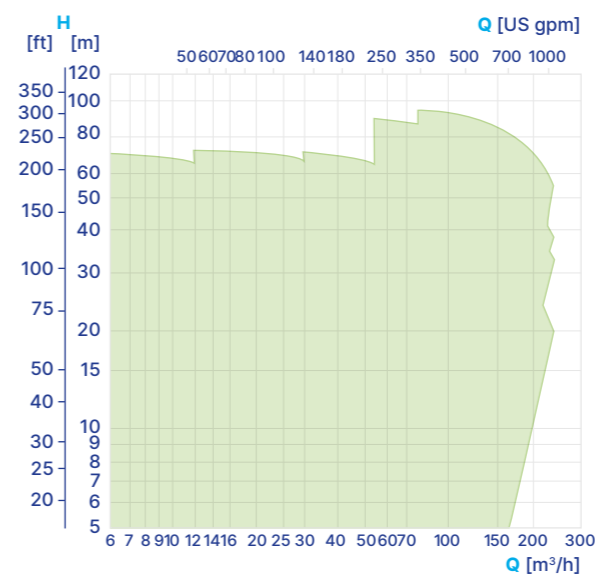

2-Pole, 50 Hz

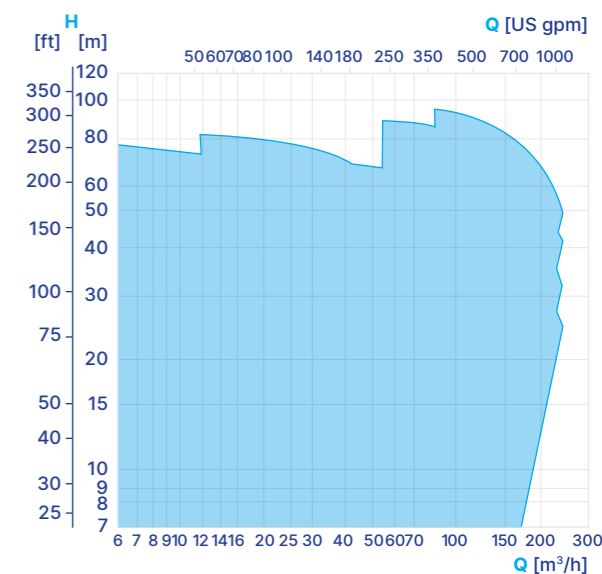

2-Pole, 60 Hz

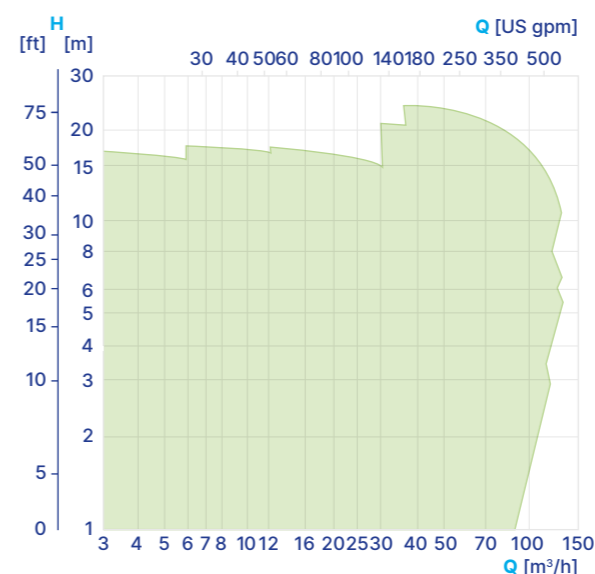

4-Pole, 50 Hz

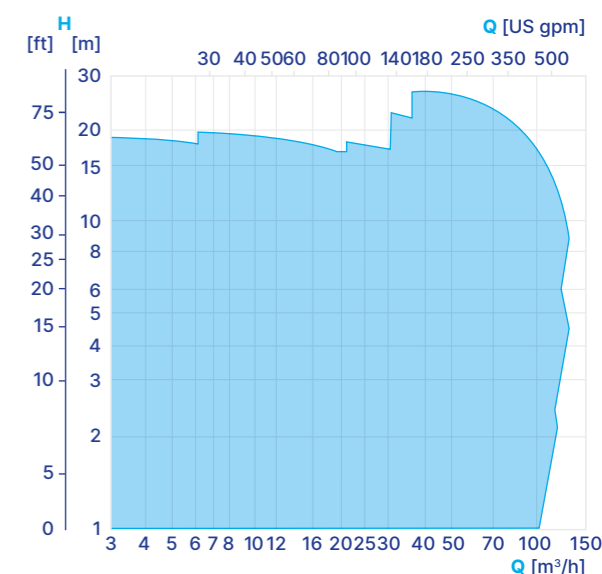

4-Pole, 60 Hz