

AP Series Motor Driven Piston Pump

OVERVIEW

The AP series is mechanical piston pump for high pressure applications in chemical dosing. Extensive build options permit great customisability to maximise economy and practicality. Unsuitable for use with abrasive liquids containing solid particles.

All pumps have manual stroke length adjustment as standard. Optional automatic stroke length adjustment accepts a 4-20 mA signal (*models with 9.3, 10, 12.3, 14, 14.5, 15 and 20 mm stroke lengths only*).

The pump is encased in grey anodized aluminium finished with an anti-acid paint.

Can be built with an ATEX Zone 2 rated motor.



AP motor pump with AISI pump head

TECHNICAL FEATURES

- Flow Rate 6 - 190 L/H
- Maximum Pressure 20 Bar (low flow rate AISI head models), 3.5 bar (highest flow rate models).
- Motor Options Single Phase, Three Phase, optional ATEX Zone 2 compatibility, optional self-ventilated motor. Accepts 230 – 400 V input at 50 Hz, single phase motors restricted to 230/110 V.
- Inverter Control Yes. Expert installation only. Requires self-ventilated motor.
- Pump Head PVC, AISI or PVDF
- Seal Material FPM, EPDM & NBR
- Thread Gas male 1/2" and 3/4"
- ATEX Rated Motor ATEX EEx-d 2G (Zone1) IIB T4 IP55 (Gas)
ATEX EEx-d 2D (Zone1) IIB T4 IP65 (Dust)
- Valves Single ball check valve (AISI only), Double ball check valve (PVC only).

4 – 20 mA CONTROL OPTIONS

AP series pumps accept two control options - inverter control or automatic stroke length control. To a 4-20 mA signal. The chart to the left displays the control signal response. The tolerance is $\pm 5\%$. Please note that this requires a separate 24 V AC power supply and is available for models with 9.3, 10, 12.3, 14, 14.5, 15 and 20 mm stroke lengths only.

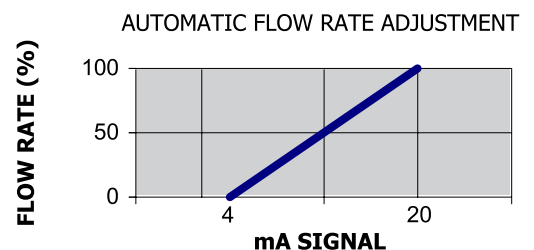

AP Series Motor Driven Piston Pump

DIMENSIONS

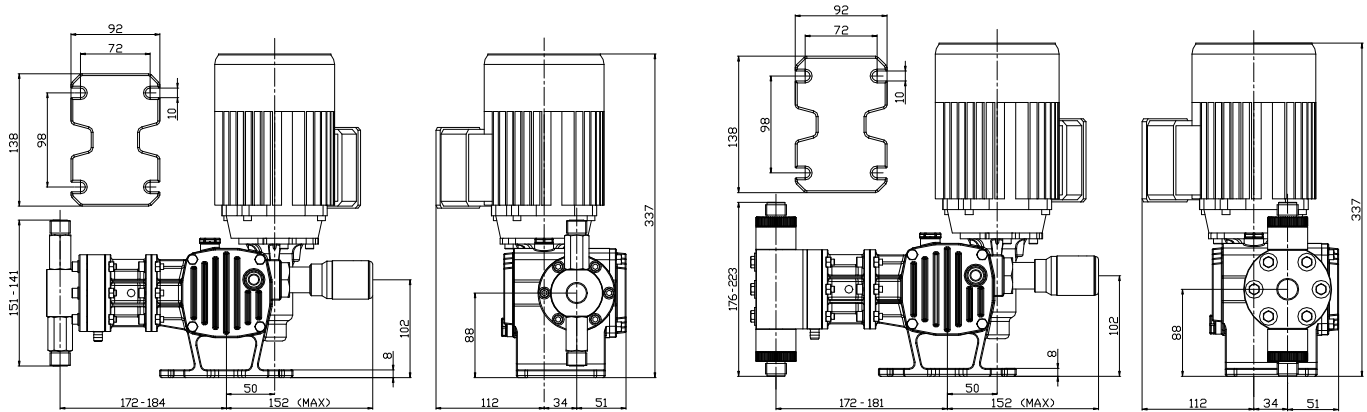

AP motor pump with AISI head

AP motor pump with PVC/PVDF Head

PRODUCT INFORMATION

Code	Flow Rate (L/H)		Pressure (Bar)				Strokes per Minute		Stroke Length (mm)	Motor Output (Kw)	Valve Size
			AISI Pump Head		PVC/PVDF Pump Head						
	50 Hz	60 Hz	50 Hz	60 Hz	50 Hz	60 Hz	50 Hz	60 Hz			
AP0006**00100	6	7	20	20	10	10	60	72	9.3	0.18	1/2" GM
AP0011**00100	11	13	20	20	10	10	60	72	15		
AP0013**00100	13	-	20	-	10	-	120	-	9.3		
AP0018**00100	18	-	20	-	10	-	120	-	12.3		
AP0022**00100	22	-	20	-	10	-	120	-	15		
AP0023**00100	23	28	13.5	11	10	10	60	72	9.3		
AP0039**00100	39	47	13.5	11	10	10	60	72	15		
AP0046**00100	46	-	10	-	10	-	120	-	9.3		
AP0064**00100	64	-	10	-	10	-	120	-	12.3		
AP0077**00100	77	-	10	-	10	-	120	-	15		
AP0058**00100	58	70	4.5	4	4.5	4	60	72	9.3	3/4" GM	
AP0095**00100	95	114	4.5	4	4.5	4	60	72	15		
AP0116**00100	116	-	3.5	-	3.5	-	120	-	9.3		
AP0157**00100	157	-	3.5	-	3.5	-	120	-	12.3		
AP0190**00100	190	-	3.5	-	3.5	-	120	-	15		

The information within this document may be subject to change without prior notice. All dimensions in mm.

Doc #: **225T01 - 20.0** 2 (2) 17/05/2017

Etatron GB Ltd
Etatron GB Ltd, Newlin Business Park, Exchange Road, Lincoln LN6 3AB
Phone: +44 (0)1522 852397
e-mail: sales@etatron.co.uk – web: www.etatron.co.uk